



LOADING LIFT TABLES



GANDHI
Automations Pvt Ltd

India's **No.1** Entrance Automation & Loading Bay Equipment Company

EUROPEAN COLLABORATION AND TECHNOLOGY WITH INNOVATIVE AND CREATIVE ENGINEERING FOR MORE THAN 25 YEARS



Quality & Safety - Our Priority

Loading Lift Tables are CE certified, manufactured in accordance with

STANDARD
EN 1570-1

DIRECTIVES : 2006/42/CE

Gandhi Automations develops and manufactures its products strictly in line with these standards. You are continuously assured safe operation with regular use, assembly and maintenance.



ISO 9001 : 2015, ISO 14001 : 2015
ISO 45001 : 2018



A PARTNER WHO STANDS BY YOUR SIDE

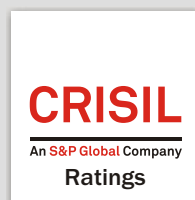

ORIGINAL SPARE PARTS
Guaranteed original spare parts availability for 10 years



Our tables comply with the European Safety of Machinery standards EN 292, Machinery Directive 2006/42/CE and Safety requirements for lift tables EN 1570.

All models include:

- Aluminium safety bar, stopping descent of the platform on contact with obstructions
- Safety clearance between scissors to prevent trapping during operation
- Safety check valve to stop the lift table lowering in the unlikely event of a hose break
- Protection against overloading
- Low voltage control box with up-down buttons and emergency stop
- Maintenance props (for safe maintenance operation)
- Removable lifting eyes to facilitate handling and lift table installation.

Our Quality For Your Safety



Gandhi Automations Pvt Ltd is India's No.1 Entrance Automation & Loading Bay Equipment Company. Since 1996, we have been designing, manufacturing, exporting and installing products that are problem free, safe and easy to operate. This is achieved due to years of hard work, innovation, commitment to quality & reliable customer service.

Our comprehensive product portfolio consist of a range of solutions :

High Speed Industrial Doors, Dock Levelers & Dock Shelters, Rolling Shutters, Sectional Overhead Doors, Aircraft Hangar Doors & Shipyard Doors, Gates & Boom Barriers

Head Office

Headquartered in Mumbai, the commercial capital of India, the company has expanded its manufacturing capacity, operations, geographical reach and customer base globally. Today our products are marketed by us and our distributors in more than 70 countries across the globe.

Competent Advice

Proper customer guidance and service are our top priorities. Our well trained and experienced specialists are always at your disposal from the project planning stage to final building inspection. They help you choose a perfect product solution tailored to meet your requirements.



Quality Management

The company caters to following certifications : ISO 9001 : 2015, ISO 14001 : 2015, ISO 45001 : 2018 by TÜV Nord. This has resulted in implementing continuous improvements towards personnel training, production, equipment calibration, machinery maintenance, logistics and customer relations.

Nationwide Network

Ahmedabad	■	Goa	■	Kolkata	■	Raipur	■
Bengaluru	■	Guwahati	■	Lucknow	■	Ranchi	■
Bhopal	■	Hyderabad	■	Mangalore	■	Surat	■
Bhubaneswar	■	Indore	■	Nagpur	■	Vadodara	■
Chandigarh	■	Jaipur	■	New Delhi	■	Visakhapatnam	■
Chennai	■	Jamshedpur	■	Patna	■		
Coimbatore	■	Kochi	■	Pune	■		



Advance Manufacturing

Our strategically located state of the art manufacturing and warehousing facility of 4,00,000 sq. ft. near Bhiwandi (40km NE of Mumbai) ensures high-quality product outputs and short delivery times.

The innovations and creative engineering applications of Gandhi Automations is a result of extensive and accurate in-house research and development.

All essential product components & accessories as well as control technology units are designed in-house and produced using European collaboration and technology.

Our product engineering team uses latest software combined with advanced machinery to offer our customers an excellent engineered, efficient and finished product.

Installation, Commissioning & Service

Our team of committed and diligent engineers and technicians are at your service continuously; many of whom are trained at advanced training centers in Europe so as to ensure perfect installation and trouble-free commissioning according to the specifications thus assuring product reliability and longevity.



Packaging & Dispatch Area

Special care and necessary precaution is taken while packaging our products for dispatch to the installation sites. Each consignment is supervised by a team of experts who ensure that material is dispatched efficiently and promptly.



Dynamic Customer Service

Our Customer Care team offers 24x7 service. We lay great emphasis on exceptional aftersales service and provide Spares, Preventive Maintenance and Annual Maintenance Contracts for minimum downtime ensuring durability and drive maximum ROI.

Our widespread service network assures response time to be minimum.

In rare case of any product failure, all you need to do is reach for the telephone.



TOLL FREE

1800 209 0200

From Anywhere in India

One call and our highly trained service technicians will be on their way in a fully equipped customer service van with wide range of original spares.

Single Scissor Lift Table for loading by forklift trucks



Used to load and unload vehicles by pedestrian or fork lift trucks without a loading dock and designed to operate with maximum safety for off-centred crossing loads;

Technical features:

- Safety tread top platform surface
- Max. 15 cycles per hour, one shift a day (for more intense operations please consult with us)
- Single acting hydraulic cylinders with drainage
- Upper travel limit switch
- Check valve on each cylinder for higher stability
- Self lubricating bearings on pivot points
- Hydraulic power pack inside the table provided with relief valve against overloading and compensated flow valve for controlled lowering speed
- Electrical equipment controlled by electronic system, with low voltage transformer and thermal overload protection
- Wide range of options available such as wheel stops, goal post barriers, safety handrails, manual bridge plates etc to meet specific requirements

Technical Specifications

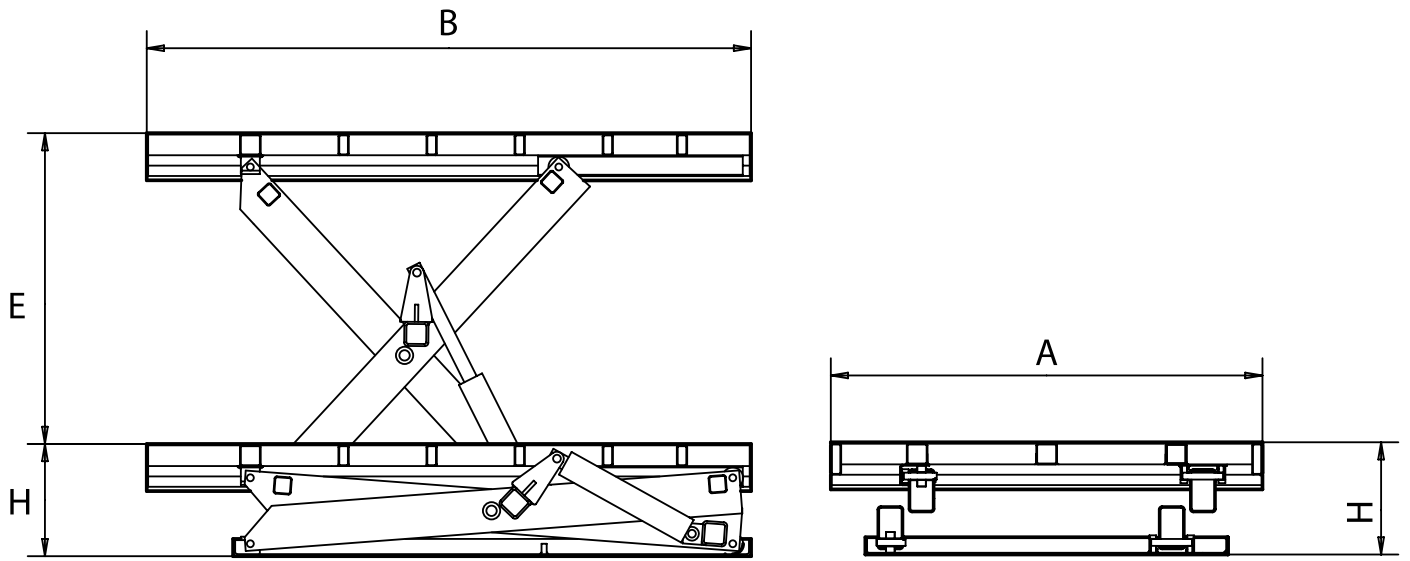

Model	Capacity kg	Platform Width A mm	Platform Length B mm	Collapsed Height H mm	Elevated Height E mm
SLT-20-2025	2000	2000	2500	350	1600
SLT-20-2030	2000	2000	3000	350	2000
SLT-20-2225	2000	2200	2500	350	1600
SLT-20-2230	2000	2200	3000	350	2000
SLT-60-2025	6000	2000	2500	550	1500
SLT-60-2030	6000	2000	3000	600	1800
SLT-60-2225	6000	2200	2500	550	1500
SLT-60-2230	6000	2200	3000	600	1800

Optional Accessories

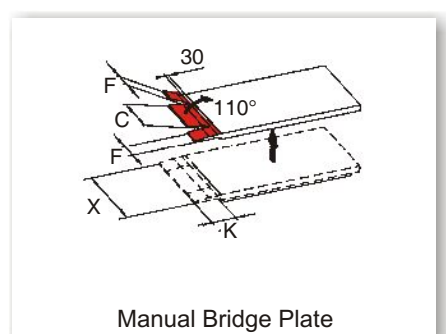
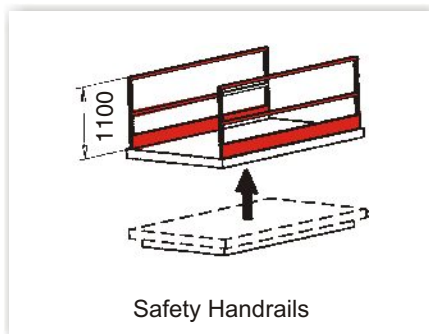
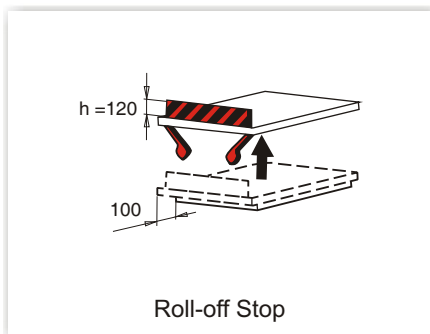
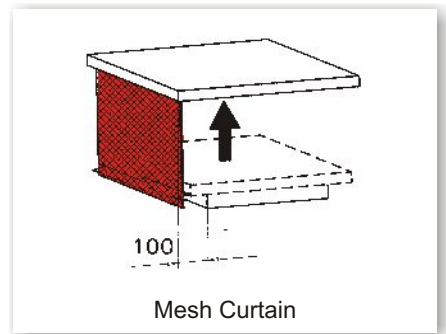
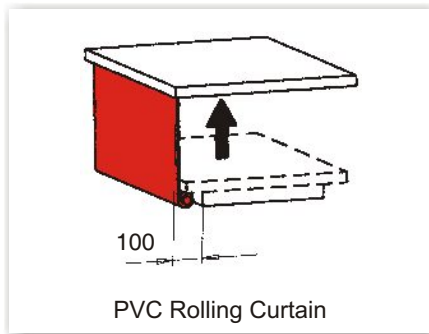
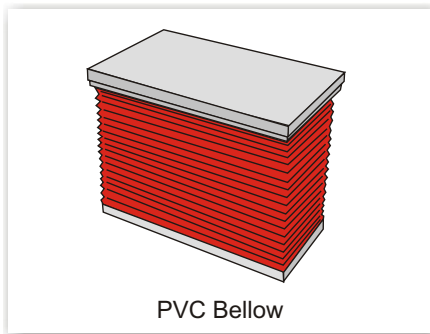



STAR EXPORT HOUSE
(Government of India Recognised)



ISO 9001 : 2015, ISO 14001 : 2015
ISO 45001 : 2018

Gandhi Automations operates a policy of continuous development and reserves the right to make technical modifications / replacements without prior notice.



Automations Pvt Ltd

India's No.1 Entrance Automation & Loading Bay Equipment Company

CORPORATE OFFICE

Chawda Commercial Centre, Link Road, Malad (W), Mumbai-400064, India

Tel : +91 22 6672 0200 / 6672 0300 (200 Lines)

Fax : +91 22 6672 0201

Email : sales@geapl.co.in

Website: www.geapl.co.in



TOLL FREE

1800 209 0200

From Anywhere in India

Ahmedabad - 93273 01555
Bengaluru - 93435 09090
Bhopal - 93292 94939
Bhubaneswar - 93385 69889
Chandigarh - 93176 41324
Chennai - 93809 31777
Coimbatore - 93452 99944
Goa - 93731 37970
Guwahati - 93248 98159

Hyderabad - 93473 75737
Indore - 93034 64410
Jaipur - 93520 41024
Jamshedpur - 93219 76556
Kochi - 93882 04774
Kolkata - 93300 60855
Lucknow - 93055 67760
Mangalore - 93797 41352
Nagpur - 93250 45410

New Delhi - 93131 99044
Patna - 93219 76557
Pune - 93245 30710
Raipur - 93524 40068
Ranchi - 93044 95570
Surat - 93270 97410
Vadodara - 93756 41357
Visakhapatnam - 93463 34102